

General Features



Properties of the TOCON_nano

- Broad Band pre-amplified UV photodetector for very low radiation
- Sensitive area $A = 12,80\text{mm}^2$, $0,22\text{ mm}^2$ SiC detector chip
- Applications: flame control and other low radiation measurements
- 1nW/cm^2 peak radiation results a voltage of approx. 280 mV
- Replacement for obsolete component Perkin Elmer UV10.T2E.10L

The TOCON pre-amplified UV photodetectors

The TOCON devices are using modern hybride technology to cancel unwanted signal disturbances caused by moisture or electromagnetic radiation. The stable 0...5V output voltage can be directly connected to a SPC controller or a voltage multimeter.

Specifications

Parameter	Symbol	Value	Unit
Maximum Ratings			
Operating Temperature Range	T_{opt}	-25 ... +85	°C
Storage Temperature Range	T_{stor}	-40 ... +100	°C
Soldering Temperature (3s)	T_{sold}	300	°C
General Characteristics (T=25°C)			
Sensitive area	A_{sens}	12,80	mm^2
Chip area	A_{chip}	0,22	mm^2
Supply voltage	V_{supply}	2,5 ... 5,0	V
max. voltage	V_{max}	5,5	V
saturation voltage	V_{sat}	5,0	V
dark offset voltage	V_{offset}	0,5	mV
Temperature coefficient	Tc	<-0,3	%/K
Current	I	0,8	mA
Bandwidth (-3 dB)	θ	15	Hz
risetime (63%)	t_{rise}	10	ms
Spectral Characteristics (T=25°C)			
Sensitivity at peak	S_{max}	280	mV/nW/cm^2
Wavelength of max. spectral sens.	λ_{max}	280	nm
Sensitivity range ($S=0,1 \cdot S_{max}$)	-	210 ... 380	nm
Visible blindness ($S_{max} / S_{>400\text{nm}}$)	VB	10^{10}	-

Spectral Response

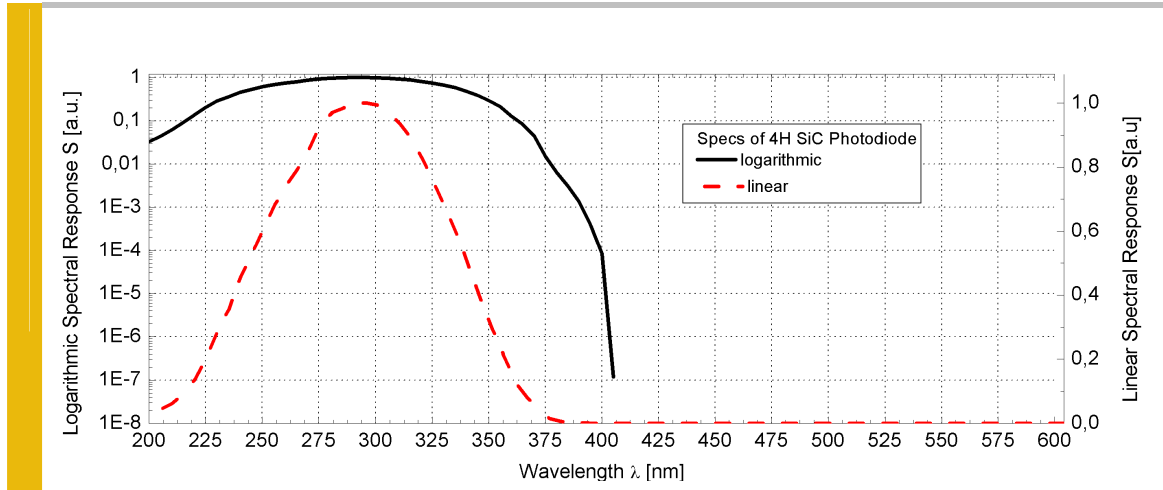

Drawing

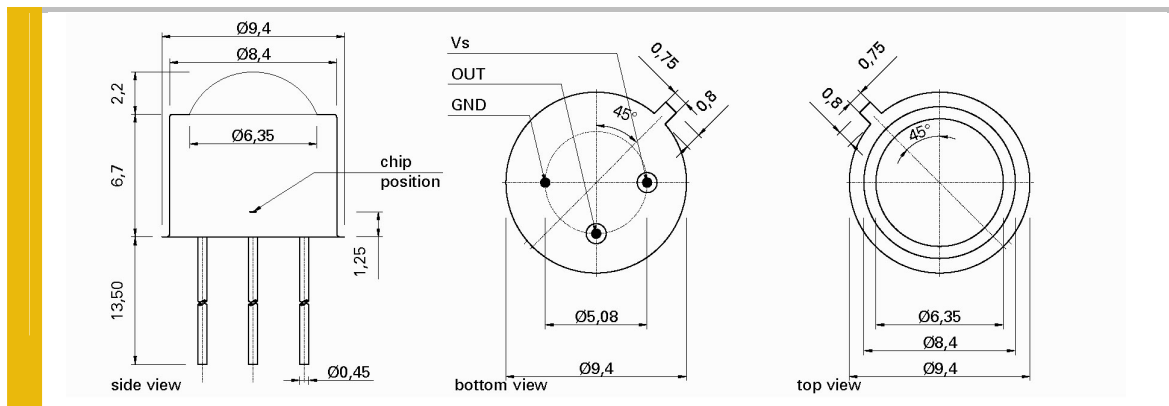

Viewing Angle

